

Communicative spring-return actuator with emergency control function for adjusting dampers in technical building installations

- Air damper size up to approx. 4 m<sup>2</sup>
- Nominal torque 20 Nm
- Nominal voltage AC/DC 24 V
- Control communicative, modulating DC (0)2...10 V Variable
- Position feedback DC 2...10 V Variable
- Conversion of sensor signals
- Communication via Belimo MP-Bus

**Technical data**

<b>Electrical data</b>	Nominal voltage	AC/DC 24 V
	Nominal voltage frequency	50/60 Hz
	Nominal voltage range	AC 19.2...28.8 V / DC 21.6...28.8 V
	Power consumption in operation	8.5 W
	Power consumption in rest position	3.5 W
	Power consumption for wire sizing	11 VA
	Connection supply / control	Cable 1 m, 4 x 0.75 mm <sup>2</sup>
	Parallel operation	Yes (note the performance data)
<b>Functional data</b>	Torque motor	Min. 20 Nm
	Torque spring return	Min. 20 Nm
	Positioning signal Y	DC 0...10 V
	Positioning signal Y note	Input impedance 100 kΩ
	Control signal Y variable	Open-close 3-point (AC only) Modulating (DC 0...32 V)
	Operating range Y	DC 2...10 V
	Operating range Y variable	Start point DC 0.5...30 V End point DC 2.5...32 V
	Position feedback U	DC 2...10 V
	Position feedback U note	Max. 0.5 mA
	Position feedback U variable	Start point DC 0.5...8 V End point DC 2.5...10 V
	Position accuracy	±5%
	Direction of motion motor	Selectable with switch L / R
	Direction of motion variable	Electronically reversible
	Direction of motion emergency control function	Selectable by mounting L / R
	Manual override	By means of hand crank and locking switch
	Angle of rotation	Max. 95°
	Angle of rotation note	adjustable starting at 33% in 2.5% steps (with mechanical end stop)
	Running time motor	150 s / 90°
	Motor running time variable	70...220 s
	Running time emergency control position	<20 s / 90°
	Running time emergency setting position note	<20 s @ -20...50°C / <60 s @ -30°C
	Adaption setting range	manual
	Adaption setting range variable	No action Adaption when switched on Adaption after pushing the gear disengagement button
	Override control	MAX (maximum position) = 100% MIN (minimum position) = 0% ZS (intermediate position, AC only) = 50%
	Override control variable	MAX = (MIN + 32%)...100% MIN = 0%...(MAX - 32%) ZS = MIN...MAX
	Sound power level motor	40 dB(A)
	Spindle driver	Universal spindle clamp 10...25.4 mm
Position indication	Mechanical	

## Technical data

<b>Functional data</b>	Service life	Min. 60,000 emergency positions
	<b>Safety</b>	Protection class IEC/EN
	Protection class UL	UL Class 2 Supply
	Degree of protection IEC/EN	IP54
	Degree of protection NEMA/UL	NEMA 2, UL Enclosure Type 2
	EMC	CE according to 2014/30/EU
	Certification IEC/EN	IEC/EN 60730-1 and IEC/EN 60730-2-14
	Certification UL	cULus according to UL 60730-1A, UL 60730-2-14 and CAN/CSA E60730-1:02
	Mode of operation	Type 1.AA
	Rated impulse voltage supply / control	0.8 kV
	Control pollution degree	3
	Ambient temperature	-30...50 °C
	Non-operating temperature	-40...80 °C
	Ambient humidity	95% r.h., non-condensing
	Maintenance	Maintenance-free
<b>Weight</b>	Weight	2.3 kg

## Safety notes



- The device must not be used outside the specified field of application, especially not in aircraft or in any other airborne means of transport.
- Outdoor application: only possible in case that no (sea)water, snow, ice, insolation or aggressive gases interfere directly with the actuator and that is ensured that the ambient conditions remain at any time within the thresholds according to the data sheet.
- Only authorised specialists may carry out installation. All applicable legal or institutional installation regulations must be complied during installation.
- The device may only be opened at the manufacturer's site. It does not contain any parts that can be replaced or repaired by the user.
- The device contains electrical and electronic components and must not be disposed of as household refuse. All locally valid regulations and requirements must be observed.
- Cables must not be removed from the device.

## Product features

<b>Mode of operation</b>	Conventional operation: The actuator is connected with a standard modulating signal of DC 0...10V and drives to the position defined by the positioning signal. Measuring voltage U serves for the electrical display of the damper position 0...100% and as slave control signal for other actuators. Operation on the MP-Bus: The actuator receives its digital positioning signal from the higher level controller via the MP-Bus and drives to the position defined. Connection U serves as communication interface and does not supply an analogue measuring voltage.
<b>Converter for sensors</b>	Connection option for a sensor (passive or active sensor or switching contact). The MP actuator serves as an analogue/digital converter for the transmission of the sensor signal via MP-Bus to the higher level system.
<b>Parameterisable actuators</b>	The factory settings cover the most common applications. Single parameters can be modified with the Belimo Service Tools MFT-P or ZTH EU.
<b>Simple direct mounting</b>	Simple direct mounting on the damper spindle with an universal spindle clamp, supplied with an anti-rotation device to prevent the actuator from rotating.
<b>Manual override</b>	By using the hand crank the damper can be actuated manually and engaged with the locking switch at any position. Unlocking is carried out manually or automatically by applying the operating voltage.
<b>High functional reliability</b>	The actuator is overload protected, requires no limit switches and automatically stops when the end stop is reached.
<b>Adjustable angle of rotation</b>	Adjustable angle of rotation with mechanical end stops.

## Product features

<b>Home position</b>	The first time the supply voltage is switched on, i.e. at the time of commissioning, the actuator carries out a synchronisation. The synchronisation is in the home position (0%). The actuator then moves into the position defined by the positioning signal.
<b>Adaption and synchronisation</b>	An adaption can be triggered manually by pressing the "Adaption" button or with the PC-Tool. Both mechanical end stops are detected during the adaption (entire setting range). Automatic synchronisation after actuating the hand crank is programmed. The synchronisation is in the home position (0%). The actuator then moves into the position defined by the positioning signal. A range of settings can be adapted using the PC-Tool (see MFT-P documentation)

## Accessories

	Description	Type
<b>Gateways</b>	Gateway MP to Modbus RTU, AC/DC 24 V	UK24MOD
	Gateway MP for BACnet MS/TP, AC/DC 24 V	UK24BAC
	Gateway MP to LonWorks, AC/DC 24 V, LonMark certified	UK24LON
	Gateway MP to KNX, AC/DC 24 V, EIBA certified	UK24EIB
<b>Electrical accessories</b>	<b>Description</b>	<b>Type</b>
	Auxiliary switch, 2 x SPDT	S2A-F
	Feedback potentiometer, 200 Ohm, incl. installation accessories	P200A-F
	Feedback potentiometer 1 kOhm, incl. installation accessories	P1000A-F
	Signal converter voltage/current, supply AC/DC 24V	Z-UIC
	Digital position indicator for front-panel mounting, 0...99%, front mass 72 x 72 mm	ZAD24
	Range controller for wall mounting, adjustable electron. Min./max. angle of rotation limitation	SBG24
	Positioner for wall mounting, range 0...100%	SGA24
	Positioner in a conduit box, range 0...100%	SGE24
	Positioner for front-panel mounting, range 0...100%	SGF24
	Positioner for wall mounting, range 0...100%	CRP24-B1
	Connecting cable 5 m, A+B: RJ12 6/6, To ZTH/ZIP-USB-MP	ZK1-GEN
	Connection cable 5 m, A: RJ11 6/4, B: Free wire end, To ZTH/ZIP-USB-MP	ZK2-GEN
	MP-Bus power supply for MP actuators, AC 230/24V for local power supply	ZN230-24MP
Connecting board MP bus suitable for wiring boxes EXT-WR-FP...-MP	ZFP2-MP	
<b>Mechanical accessories</b>	<b>Description</b>	<b>Type</b>
	Shaft extension 250 mm, for damper spindles Ø 8...25 mm	AV8-25
	End stop indicator for NF..A / SF..A	IND-AFB
	Spindle clamp set for NF..A/SF..A (1", 3/4", 1/2")	K7-2
	Straight ball joint with M8, suitable for damper crank arms KH8	KG10A
	Angled ball joint with M8, suitable for damper crank arms KH8	KG8
	Damper crank arm, for damper spindles	KH8
	Damper crank arm for NF..A / SF..A, for 3/4" spindles	KH-AFB
	Form fit insert 10x10 mm, for spring return actuators NG	ZF10-NSA-F
	Form fit insert 12x12 mm, for spring return actuators NG	ZF12-NSA-F
	Form fit insert 16x16 mm, for spring return actuators NG	ZF16-NSA-F
	Damper crank arm, for spring return actuators NG	ZG-AFB
	Base plate extensions for NF..A/SF..A	Z-SF
<b>Service Tools</b>	<b>Description</b>	<b>Type</b>
	Service Tool, for MF/MP/Modbus/LonWorks actuators and VAV-Controller	ZTH EU
	Belimo PC-Tool, software for adjustments and diagnostics	MFT-P
Adapter to Service Tool ZTH	MFT-C	

**Electrical installation**



**Notes**

- Connection via safety isolating transformer.
- Parallel connection of other actuators possible. Observe the performance data.

**Wiring diagrams**

AC/DC 24 V, modulating

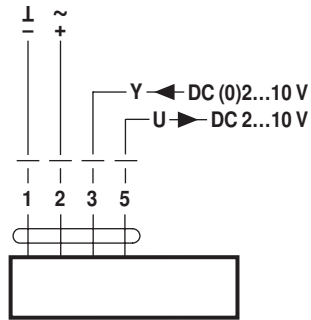

**Cable colours:**

- 1 = black
- 2 = red
- 3 = white
- 5 = orange

Operation on the MP-Bus

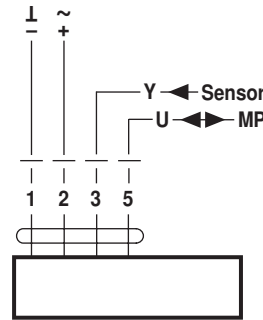

**Cable colours:**

- 1 = black
- 2 = red
- 3 = white
- 5 = orange

**Functions**

**Functions when operated on MP-Bus**

Connection on the MP-Bus

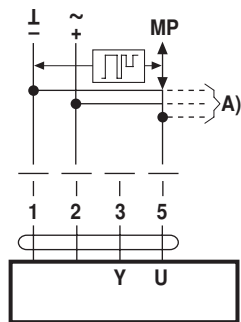

A) more actuators and sensors (max.8)

Network topology

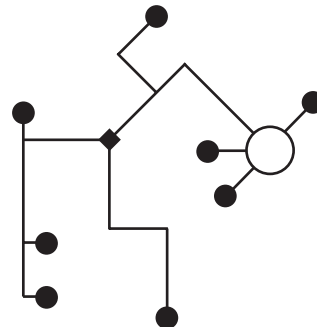

There are no restrictions for the network topology (star, ring, tree or mixed forms are permitted).  
Supply and communication in one and the same 3-wire cable

- no shielding or twisting necessary
- no terminating resistors required

Connection of active sensors

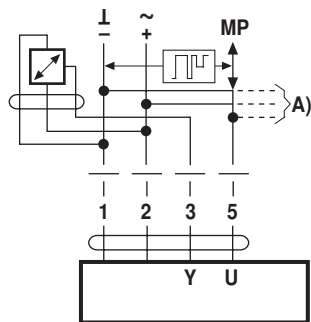

A) more actuators and sensors (max.8)

- Supply AC/DC 24 V
- Output signal DC 0...10 V (max. DC 0...32 V)
- Resolution 30 mV

Connection of external switching contact

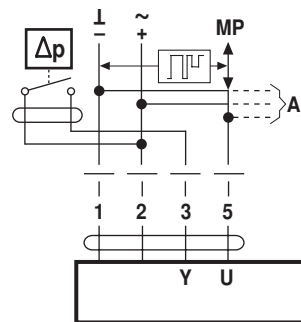

A) more actuators and sensors (max.8)

- Switching current 16 mA @ 24 V
- Start point of the operating range must be parameterised on the MP actuator as  $\geq 0.5$  V

Connection of passive sensors

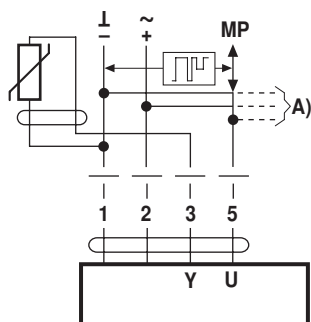

Ni1000	-28...+98 °C	850...1600 $\Omega^2$ )
PT1000	-35...+155 °C	850...1600 $\Omega^2$ )
NTC	-10...+160 °C 1)	200 $\Omega$ ...60 k $\Omega^2$ )

A) more actuators and sensors (max.8)

1) Depending on the type  
2) Resolution 1 Ohm

Functions

Functions with basic values (conventional mode)

Override control with AC 24 V with relay contacts

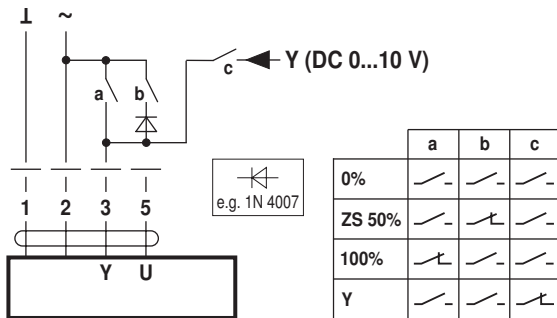

Override control with AC 24 V with rotary switch

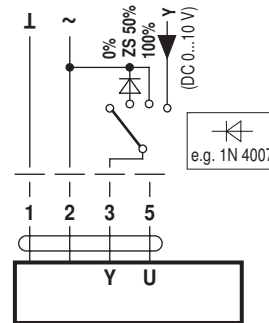

Remote control 0...100% with positioner SG..

Minimum limit with positioner SG..

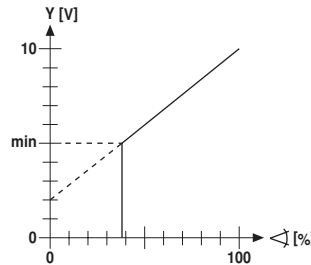
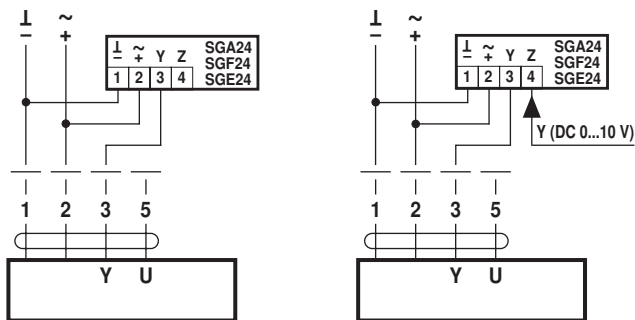

Follow-up control (position-dependent)

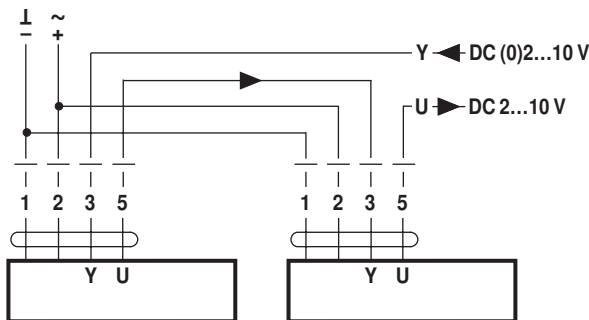

Position indication

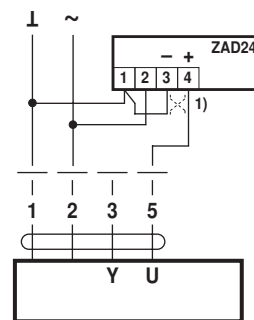

(1) Adapting the direction of rotation

Control with 4...20 mA via external resistor

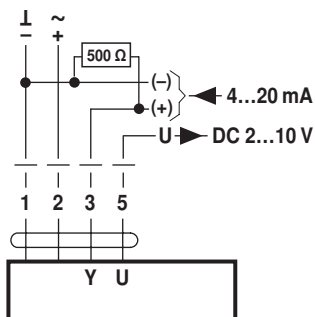

**Caution:**  
The operating range must be set to DC 2...10 V.  
The 500 Ω resistor converts the 4...20 mA current signal to a voltage signal DC 2...10 V

Functional check

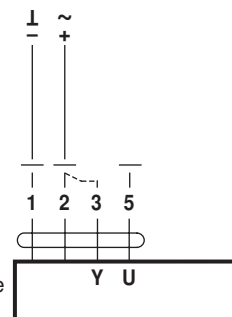

**Procedure**

1. Connect 24V to connections 1 and 2
2. Disconnect connection 3:
  - with direction of rotation 0: Actuator rotates to the left
  - with direction of rotation 1: Actuator rotates to the right
3. Short-circuit connections 2 and 3:
  - Actuator runs in opposite direction

**Functions**

**Functions for actuators with specific parameters (Parametrisation with PC-Tool necessary)**

Override control and limiting with AC 24 V with relay contacts

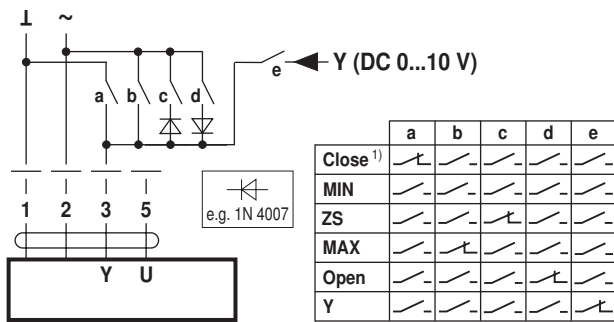

Override control and limiting with AC 24 V with rotary switch

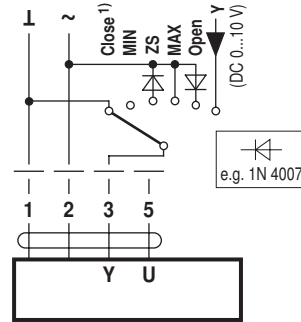

1) **Caution:** This function is only guaranteed if the start point of the operating range is defined as min. 0.5 V.

Control open-close

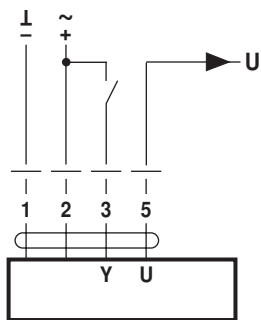

Control 3-point

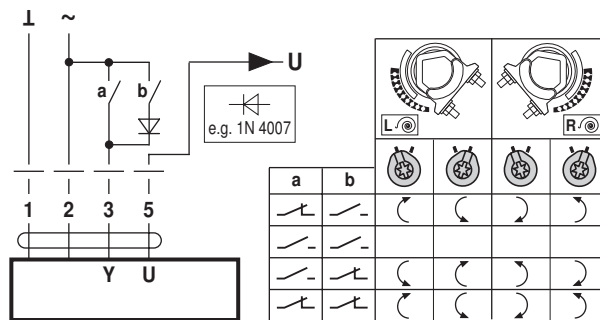

**Operating controls and indicators**

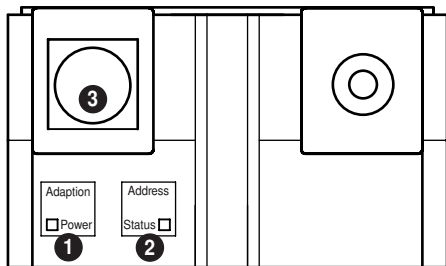

- 1 Membrane key and LED display green**  
 Off: No power supply or malfunction  
 On: In operation  
 Press button: Triggers angle of rotation adaptation, followed by standard mode
- 2 Membrane key and LED display gelb**  
 Off: Standard mode  
 Flickering: MP communication active  
 On: Adaptation and synchronising process active  
 Flashing: Request for addressing from MP master  
 Press button: Confirmation of the addressing
- 3 Service plug**  
 For connecting parameterisation and service tools

**Operating elements**

The manual override, locking switch and direction of rotation switch elements are available on both sides

Service

**Service Tools connection** The actuator can be parameterised by ZTH EU via the service socket. For an extended parameterisation the PC tool can be connected.

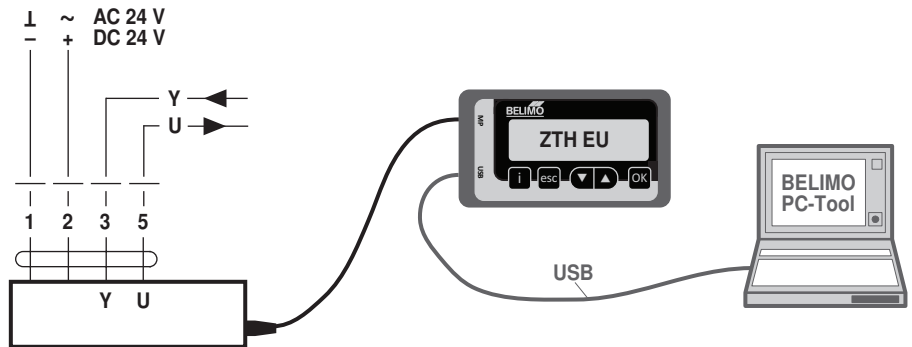

Dimensions [mm]

Spindle length

		Min. 85
		Min. 15

Clamping range

	10...22	10	14...25.4
	19...25.4	12...18	

Dimensional drawings

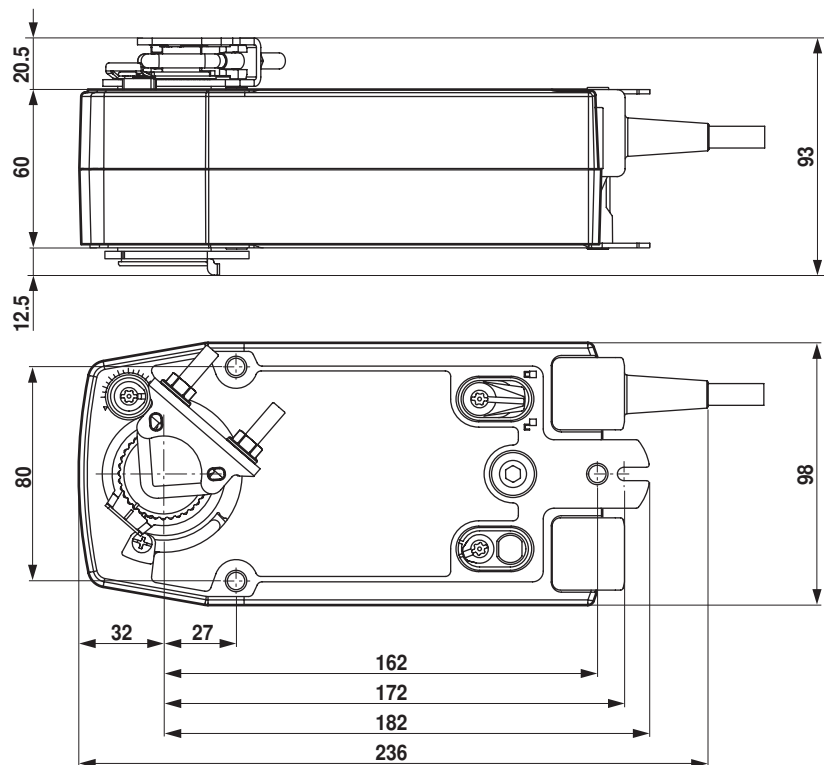

Further documentation

- Overview MP Cooperation Partners
- Tool connections