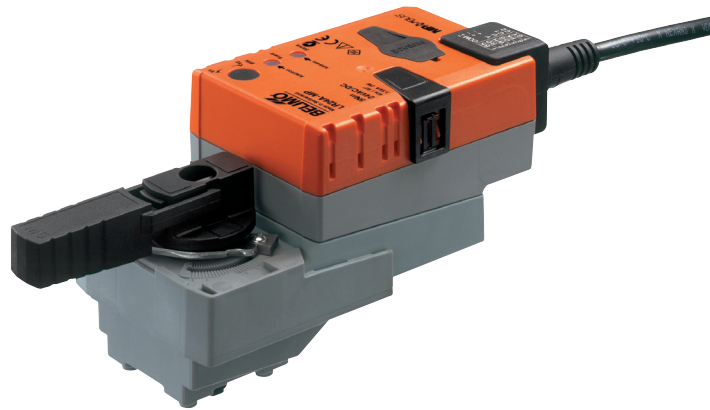

Communicative rotary actuator for ball valves

- Nominal torque 5 Nm
- Nominal voltage AC/DC 24 V
- Conversion of sensor signals
- Communication via KNX (S-Mode)

**Technical data**

|                               |   |  |
|-------------------------------|---|--|
| <b>Electrical data</b>        | Nominal voltage                         | AC/DC 24 V   |
|                               | Nominal voltage frequency               | 50/60 Hz   |
|                               | Nominal voltage range                   | AC 19.2...28.8 V / DC 21.6...28.8 V  |
|                               | Power consumption in operation          | 2.5 W  |
|                               | Power consumption in rest position      | 1.3 W  |
|                               | Power consumption for wire sizing       | 5 VA   |
|                               | Connection supply / control             | Cable 1 m, 6 x 0.75 mm <sup>2</sup>  |
| <b>Data bus communication</b> | Medium                                  | KNX TP   |
|                               | Number of nodes                         | max. 64 per line segment, reduce number of nodes with connection cable with short lines          |
|                               | Operating mode                          | S-Mode   |
|                               | Stromaufnahme von KNX-Bus               | Max. 5 mA  |
|                               | Projektierungs- und Inbetriebnahme-Tool | ETS4 or higher   |
| <b>Functional data</b>        | Torque motor                            | Min. 5 Nm  |
|                               | Position accuracy                       | ±5%  |
|                               | Manual override                         | with push-button, can be locked  |
|                               | Running time motor                      | 90 s / 90°   |
|                               | Motor running time variable             | 35...420 s   |
|                               | Adaption setting range                  | manual (automatic on first power-up)   |
|                               | Adaption setting range variable         | No action<br>Adaption when switched on<br>Adaption after pushing the gear disengagement button   |
|                               | Override control, controllable via KNX  | MAX (maximum position) = 100%<br>MIN (minimum position) = 0%<br>ZS (intermediate position) = 50% |
|                               | Override control variable               | MAX = (MIN + 33%)...100%<br>MIN = 0%...(MAX - 33%)<br>ZS = MIN...MAX                             |
|                               | Sound power level motor                 | 35 dB(A)   |
| Position indication           | Mechanically, pluggable                 |  |
| <b>Safety</b>                 | Protection class IEC/EN                 | III Safety Extra-Low Voltage (SELV)  |
|                               | Degree of protection IEC/EN             | IP54   |
|                               | EMC                                     | CE according to 2014/30/EU   |
|                               | Certification IEC/EN                    | IEC/EN 60730-1 and IEC/EN 60730-2-14   |
|                               | Mode of operation                       | Type 1   |
|                               | Rated impulse voltage supply / control  | 0.8 kV   |
|                               | Control pollution degree                | 3  |
|                               | Ambient temperature                     | 0...50 °C  |
|                               | Non-operating temperature               | -40...80 °C  |
|                               | Ambient humidity                        | 95% r.h., non-condensing   |
| Maintenance                   | Maintenance-free                        |  |
| <b>Weight</b>                 | Weight                                  | 0.63 kg  |

## Safety notes



- This device has been designed for use in stationary heating, ventilation and air conditioning systems and must not be used outside the specified field of application, especially in aircraft or in any other airborne means of transport.
- Outdoor application: only possible in case that no (sea)water, snow, ice, insolation or aggressive gases interfere directly with the actuator and that is ensured that the ambient conditions remain at any time within the thresholds according to the data sheet.
- Only authorised specialists may carry out installation. All applicable legal or institutional installation regulations must be complied during installation.
- The switch for changing the direction of rotation may only be operated by authorised specialists. The direction of rotation must not in particular be reversed in a frost protection circuit.
- The device may only be opened at the manufacturer's site. It does not contain any parts that can be replaced or repaired by the user.
- Cables must not be removed from the device.
- The device contains electrical and electronic components and must not be disposed of as household refuse. All locally valid regulations and requirements must be observed.

## Product features

|                                     |   |
|-------------------------------------|---|
| <b>Mode of operation</b>            | The actuator is equipped with an integrated interface for KNX (S-Mode) and can be connected with all KNX devices that have corresponding data points available.   |
| <b>Converter for sensors</b>        | Connection option for a sensor (passive or active sensor or switching contact). In this way, the analogue sensor signal can be easily digitised and passed along to KNX.  |
| <b>Parameterisable actuators</b>    | The factory settings cover the most common applications. As desired, individual parameters can be adapted for specific systems or servicing with a service tool (e.g. ZTH EU) or the ETS planning and commissioning tool.   |
| <b>Simple direct mounting</b>       | Straightforward direct mounting on the ball valve with only one central screw. The assembly tool is integrated in the plug-in position indication. The mounting orientation in relation to the ball valve can be selected in 90° steps.   |
| <b>Manual override</b>              | Manual override with push-button possible (the gear is disengaged for as long as the button is pressed or remains locked).  |
| <b>Adjustable angle of rotation</b> | Adjustable angle of rotation with mechanical end stops.   |
| <b>High functional reliability</b>  | The actuator is overload protected, requires no limit switches and automatically stops when the end stop is reached.  |
| <b>Home position</b>                | The first time the supply voltage is switched on, i.e. at the time of commissioning, the actuator carries out an adaption, which is when the operating range and position feedback adjust themselves to the mechanical setting range.<br>The actuator then moves into the position defined by the positioning signal.<br>Factory setting: Y2 (counter-clockwise rotation).  |
| <b>Adaption and synchronisation</b> | An adaption can be triggered manually by pressing the "Adaption" button or with the PC-Tool. Both mechanical end stops are detected during the adaption (entire setting range).<br>Automatic synchronisation after pressing the gearbox disengagement button is configured. The synchronisation is in the home position (0%).<br>The actuator then moves into the position defined by the positioning signal.<br>A range of settings can be adapted using the PC-Tool (see MFT-P documentation) |

Accessories

|                        | Description  | Type    |
|------------------------|--|---------|
| Electrical accessories | Connection cable 5 m, A+B: RJ12 6/6, To ZTH/ZIP-USB-MP   | ZK1-GEN |
|                        | Connection cable 5 m, A: RJ11 6/4, B: Free wire end, To ZTH/ZIP-USB-MP   | ZK2-GEN |
| Service Tools          | Description  | Type    |
|                        | Service tool for parametrisable and communicative Belimo actuators / VAV controller and HVAC performance devices | ZTH EU  |
|                        | Belimo PC-Tool, software for adjustments and diagnostics   | MFT-P   |
|                        | Adapter to Service Tool ZTH  | MFT-C   |

Electrical installation

**Notes**

- Connection via safety isolating transformer.
- Parallel connection of other actuators possible. Observe the performance data.
- Direction of rotation switch is covered. Factory setting: Direction of rotation Y2.

Wiring diagrams

Connection without sensor

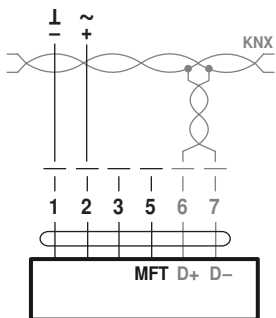

Signal assignment KNX:  
D+ = KNX+ (pink > red)  
D- = KNX- (grey > black)  
The connection to the KNX line should take place via WAGO connecting terminals 222/221.

Connection with passive sensor, e.g. Pt1000, Ni1000, NTC

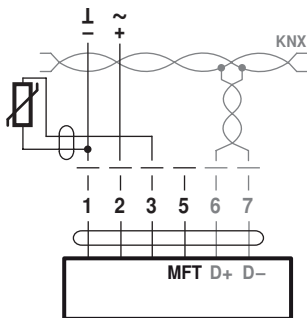

|        |                             |                             |
|--------|-----------------------------|-----------------------------|
| Ni1000 | -28...+98 °C                | 850...1600 Ω <sup>2)</sup>  |
| PT1000 | -35...+155 °C               | 850...1600 Ω <sup>2)</sup>  |
| NTC    | -10...+160 °C <sup>1)</sup> | 200 Ω...60 kΩ <sup>2)</sup> |

1) depending on type  
2) Resolution 1 Ohm

Connection with switching contact, e.g. pressure control device

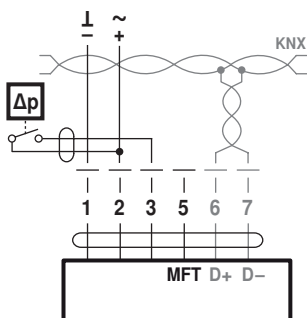

Requirements switching contact:  
The switching contact must be able to accurately switch a current of 16 mA@24 V.

Connection with active sensor, e.g. 0...10 V @ 0...50 °C

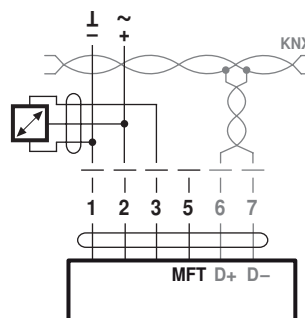

Possible voltage range:  
0...32 V (resolution 30 mV)

## KNX Group Objects

| Name                | Type | Flags |   |   |   |   | Data point type |                               |        |         | Values range  |
|---------------------|------|-------|---|---|---|---|-----------------|-------------------------------|--------|---------|---|
|                     |      | C     | R | W | T | U | ID              | DPT_Name                      | Format | Unit    |   |
| Setpoint            | I    | C     | - | W | - | - | 5.001           | _Scaling                      | 1 Byte | %       | [0...100]<br>Resolution 0.4%  |
| Override control    | I    | C     | - | W | - | - | 20.*            | _Enum                         | 1 Byte | -       | 0 = no override<br>1 = Open<br>2 = Closed<br>3 = Min<br>4 = Mid<br>5 = Max  |
| Reset               | I    | C     | - | W | - | - | 1.015           | _Reset                        | 1 Bit  | -       | 0 = no action<br>1 = reset  |
| Adaptation          | I    | C     | - | W | - | - | 1.017           | _Switch                       | 1 Bit  | -       | 0 = no action<br>1 = adapt  |
| Testrun             | I    | C     | - | W | - | - | 1.017           | _Switch                       | 1 Bit  | -       | 0 = no action<br>1 = Testrun  |
| Min                 | I/O  | C     | R | W | - | - | 5.001           | _Scaling                      | 1 Byte | %       | [0...100]<br>Resolution 0.4%  |
| Max                 | I/O  | C     | R | W | - | - | 5.001           | _Scaling                      | 1 Byte | %       | [0...100]<br>Resolution 0.4%  |
| Relative position   | O    | C     | R | - | T | - | 5.001           | _Scaling                      | 1 Byte | %       | [0...100]<br>Resolution 0.4%  |
| Absolute position   | O    | C     | R | - | T | - | 8.011<br>7.011  | _Rotation_Angle<br>_Length_mm | 2 Byte | °<br>mm | [-32,768...32,768]<br>[0...65,535]  |
| Fault state         | O    | C     | R | - | T | - | 1.002           | _Bool                         | 1 Bit  | -       | 0 = no fault<br>1 = fault   |
| Overridden          | O    | C     | R | - | T | - | 1.002           | _Bool                         | 1 Bit  | -       | 0 = not active<br>1 = active  |
| Gear disengaged     | O    | C     | R | - | T | - | 1.002           | _Bool                         | 1 Bit  | -       | 0 = engaged<br>1 = disengaged   |
| Service information | O    | C     | R | - | T | - | 22.*            | _Bitset16                     | 2 Byte | -       | Bit 0 (1) Excessive utilisation<br>Bit 1 (2) Mechanical travel increased<br>Bit 2 (4) Mechanical overload<br>Bit 3 (8) – (Not used)<br>Bit 4 (16) – (Not used)<br>Bit 5 (32) – (Not used)<br>Bit 6 (64) – (Not used)<br>Bit 7 (128) – (Not used)<br>Bit 8 (256) Internal activity<br>Bit 9 (512) Bus watchdog triggered |
| Sensor value        | O    | C     | R | - | T | - |                 |                               |        |         |   |
| - Resistance R      |      |       |   |   |   |   | 14.060          | _Value_Resistance             | 4 Byte | Ω       | -   |
| - Temperature       |      |       |   |   |   |   | 9.001           | _Value_Temp                   | 2 Byte | °C      | [-273.....670'760]  |
| - Relative humidity |      |       |   |   |   |   | 9.007           | _Value_Humidity               | 2 Byte | % rH    | [0...670'760]   |
| - Air quality       |      |       |   |   |   |   | 9.008           | _Value_AirQuality             | 2 Byte | ppm     | [0...670'760]   |
| - Voltage mV        |      |       |   |   |   |   | 9.020           | _Value_Voltage                | 2 Byte | mV      | [-670'760...670'760]  |
| - Voltage scaled    |      |       |   |   |   |   | 7.*             | -                             | 2 Byte | -       | [0...65'535]  |
| - Voltage scaled %  |      |       |   |   |   |   | 5.001           | _Scaling                      | 1 Byte | %       | [0...100]   |
| - Switch            |      |       |   |   |   |   | 1.001           | _Switch                       | -      | -       | 0/1   |

## KNX Group Objects

|                            |  |
|----------------------------|--|
| <b>Setpoint</b>            | Specification of actuator position in % between the parameterised Min and Max limits.  |
| <b>Override control</b>    | Overriding the setpoint with defined override states.<br>As data point type, 1 Byte (unsigned) is recommended (DPT 20.*)   |
| <b>Reset</b>               | Resetting the stored service messages<br>(see KNX group object <i>Service information</i> ).   |
| <b>Adaptation</b>          | Perform the adaptation.<br>An active adaptation is signaled in Bit 8 of <i>Service information</i> .   |
| <b>Testrun</b>             | Performance of a testrun that checks the entire operating range.<br>An active testrun is signaled in Bit 8 of <i>Service information</i> . After completion, detected faults (mechanical overload, mechanical travel increased) are signaled in <i>Service Information</i> .   |
| <b>Min</b>                 | Minimum Limit (position) in %.<br>Caution: Changing the setting may result in malfunctions.  |
| <b>Max</b>                 | Maximum Limit (position) in %.<br>Caution: Changing the setting may result in malfunctions.  |
| <b>Relative position</b>   | Current actuator position in %   |
| <b>Absolute position</b>   | Absolute position/stroke<br>The data point type is to be selected depending on the type of movement:<br>[°] DPT 8.011<br>[mm] DPT 7.011  |
| <b>Fault state</b>         | Collective fault based on Bit 0 ... Bit 7 of <i>Service information</i>  |
| <b>Overridden</b>          | Signaling of an active override control (OPEN/CLOSED)<br>The device can be commanded via the KNX group object <i>Override control</i> or via the forced switching at the input Y/3. Only the override controls OPEN and CLOSED are signaled.   |
| <b>Gear disengaged</b>     | Signaling an active gear disengagement   |
| <b>Service information</b> | Detailed information regarding device status<br>As data point type, Bitset 16-Bit is recommended (DPT 22.*)<br>Status information<br>Bit 0: Motor operation in relation to operating period too high<br>Bit 1: Mechanical travel increased, e.g. defined end position exceeded<br>Bit 2: Mechanical overload, i.e. defined end position not reached<br>Bit 3 ... 7: not used with this device type<br>Bit 8: Internal activity (Synchronisation, Adaptation, Testrun, ...)<br>Bit 9: Bus watchdog triggered<br>Bit 0 ... Bit 7 are stored by the device and can be reset with the KNX group object <i>Reset</i> . As an alternative, the several bits can be read as collective fault state. |
| <b>Sensor value</b>        | The representation of the sensor value is dependent on the parameterization.<br>See section "KNX parameters – Sensor"  |

## KNX Parameters

## Common

**Setpoint at bus failure** A setpoint can be defined for cases of communication interruption.  
 Values range: None (last setpoint)  
 Open  
 Closed  
 Mid  
 Factory setting: None (last setpoint)  
 The monitoring of the communication takes place for the KNX group objects *Setpoint* and *Override control*. If none of the objects is written within the parameterised monitoring time, the bus fail position is set and signaled in the *Service information* (Bit 9).

**Bus timeout [min]** Monitoring time for the detection of a communication interruption.  
 Values range: 1 ... 120 min  
 Factory setting: –

**Increment for value update [%]** Actual values (position, volumetric flow) are transferred at the time of a value change insofar as these change by the parameterised difference value. If the relative value changes by the difference value, not only the relative actual value but also the absolute actual value are transferred.  
 Values range: 0 ... 100%  
 Factory setting: 5%  
 The transfer is deactivated with 0% in the event of a value change.

**Repetition time [s]** Repetition time for all position and sensor actual values. Status objects are not transferred except with a change.  
 Values range: 0 ... 3600 s  
 Factory setting: 0 = no periodic transmission

## Sensor

**Sensor type** The input Y/3 can be used to connect a sensor. The sensor value is digitised and made available as KNX communication object.  
 Values range: No sensor  
 Active sensor (0 ... 32 V)  
 Passive sensor (1 K / 20 K)  
 Temperature sensor (PT1000 / Ni1000 / NTG10K)  
 Switch (0 / 1)  
 Humidity sensor (0-10 V corresponds to 0 – 100%)  
 Air quality sensor CO2 (0-10 V corresponds to 0 – 2000 ppm)  
 Factory setting: No sensor  
 A switching to Y/3 is treated as local override in the absence of sensor parameterization.

**Increment for sensor value update** The sensor value is transferred at the time of a value change insofar as this changes by the parameterised difference value.  
 Values range: 0 ... 65,535  
 Factory setting: 1  
 The transfer is deactivated with 0 in the event of a value change. Without value change, the sensor value is sent because of the repetition time.

**Output** (for sensor type "Active sensor") Only for "Active sensor" sensor type  
 Values range: Sensor value mV (DPT 9.020)  
 Sensor value scaled (DPT 7.xxx)  
 Sensor value scaled % (DPT 5.001)  
 Factory setting: –  
 For "Sensor value mV", the measured voltage is made available without processing. In the case of the scaled sensor values, a linear transformation can be defined with two points.

**Polarity** (for sensor type "Switch") The polarity can be defined for the sensor type "Switch".  
 Values range: Normal  
 Inverted  
 Factory setting: –

**KNX Work Procedures**

- Product database** The product database for the import in ETS4 or higher is available at the Belimo website [www.belimo.eu](http://www.belimo.eu) (Download Center)
- Setting physical address** The programming of the physical address takes place by ETS and the programming button on the device.  
If the programming button is not accessible or accessible only with difficulty, then the address can be set using a point-to-point connection: "Overwrite Individual Address: 15.15.255"  
As a third possibility, the physical address can be programmed on the basis of the KNX series number (e.g. with Moov'n'Group). The KNX series number is placed on the device in two versions. One sticker can be removed for adhesion on the commissioning journal, for example.
- Firmware upgrade** The KNX firmware of the device is updated automatically with the programming of the application program insofar as the product database has a more recent version.  
The first programming procedure takes somewhat longer in such cases (>1 min).
- Resetting to KNX factory settings** If necessary, the device can be reset manually to the KNX factory settings (physical address, group address, KNX parameters).  
For the reset, the programming button on the device must be pressed down for at least 5 s during start-up.

**Operating controls and indicators**

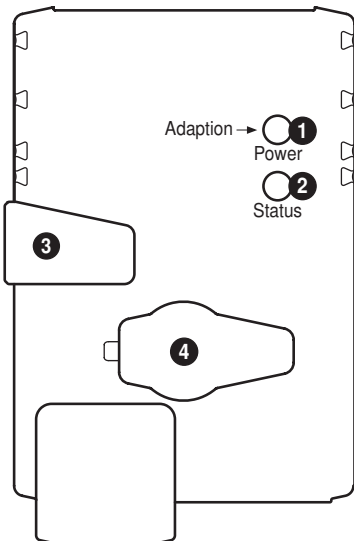

- 2 Push-button and LED display green**  
Off: No power supply or malfunction  
On: In operation  
Press button: Triggers angle of rotation adaptation
- 3 Push-button and LED display yellow**  
Off: The actuator is ready  
On: Adaptation or synchronising process active or actuator in programming mode (KNX)  
Flashing: Connection test (KNX) active  
Press button: In operation (>1 s): Switch the programming mode on and off (KNX)  
When starting (>5 s): Reset to factory setting (KNX)
- 4 Gear disengagement button**  
Press button: Gear disengages, motor stops, manual override possible  
Release button: Gear engages, synchronisation starts, followed by standard mode
- 5 Service plug**  
For connecting parameterisation and service tools

**Service**

**Notes** • The actuator can be parameterised by PC-Tool and ZTH EU via the service socket.

**Service Tools connection** The actuator can be parameterised by ZTH EU via the service socket. For an extended parameterisation the PC tool can be connected.

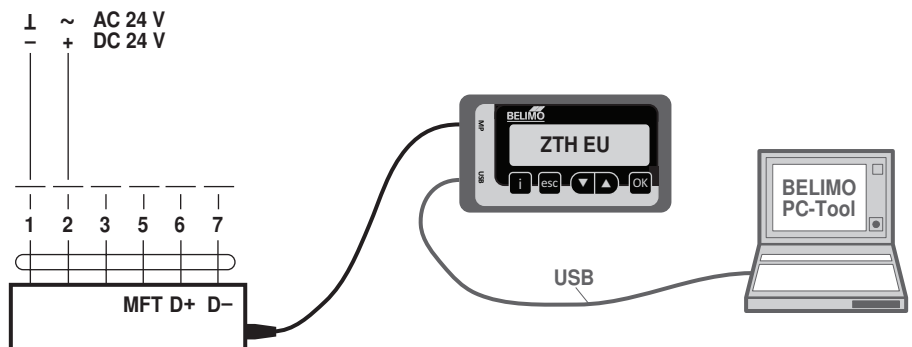

## Dimensions [mm]

## Dimensional drawings

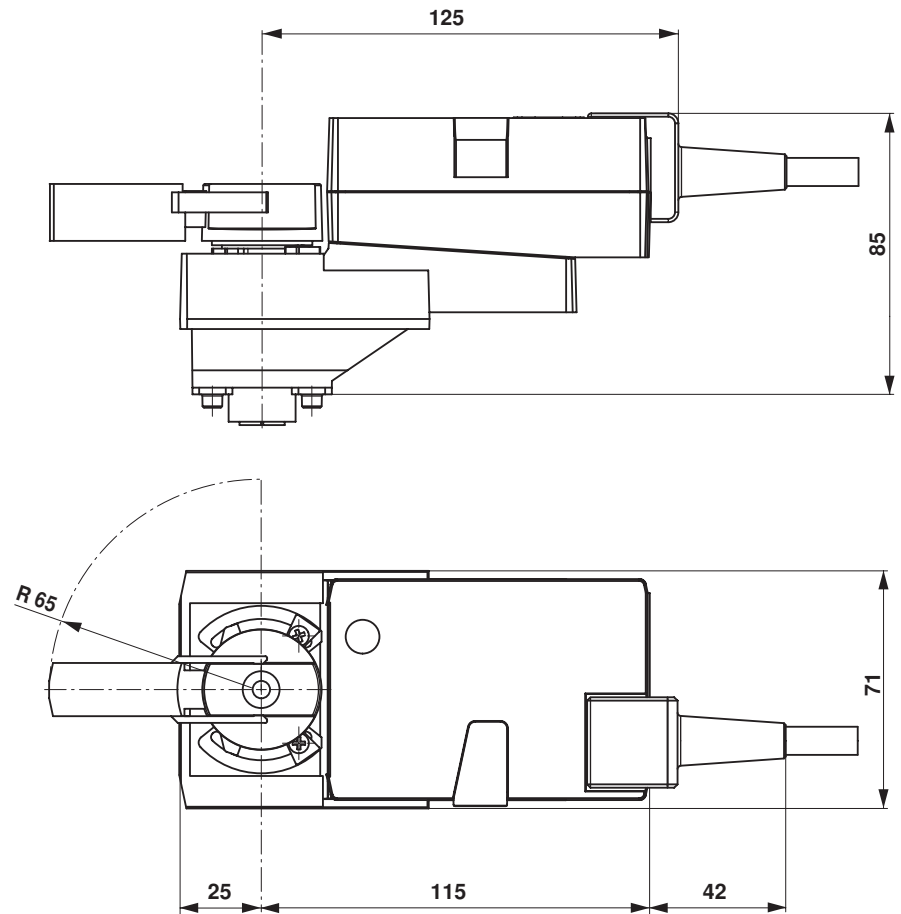

## Further documentation

- Tool connections
- Overview Valve-actuator combinations
- Data sheets for ball valves
- Installation instructions for actuators and/or ball valves
- General notes for project planning