

Modulating damper actuator for adjusting dampers in technical building installations

- Air damper size up to approx. 0.4 m<sup>2</sup>
- Nominal torque 2 Nm
- Nominal voltage AC/DC 24 V
- Control modulating DC (0)2...10 V
- Position feedback DC 2...10 V
- Spindle driver Form fit 8x8 mm

**Technical data**

<b>Electrical data</b>	Nominal voltage	AC/DC 24 V
	Nominal voltage frequency	50/60 Hz
	Nominal voltage range	AC 19.2...28.8 V / DC 19.2...28.8 V
	Power consumption in operation	1 W
	Power consumption in rest position	0.5 W
	Power consumption for wire sizing	1.5 VA
	Connection supply / control	Cable 1 m, 4 x 0.75 mm <sup>2</sup>
	Parallel operation	Yes (note the performance data)
<b>Functional data</b>	Torque motor	Min. 2 Nm
	Positioning signal Y	DC 0...10 V
	Positioning signal Y note	Input impedance 100 kΩ
	Operating range Y	DC 2...10 V
	Position feedback U	DC 2...10 V
	Position feedback U note	Max. 1 mA
	Position accuracy	±5%
	Direction of motion motor	cw rotation
	Direction of motion note	Y = 0 V: right end stop, position 0
	Manual override	with magnet
	Angle of rotation	95°, fixed setting
	Running time motor	75 s / 90°
	Sound power level motor	35 dB(A)
	Spindle driver	Form fit 8x8 mm
Position indication	Mechanically, pluggable (with integrated magnet for gear disengagement)	
<b>Safety</b>	Protection class IEC/EN	III Safety Extra-Low Voltage (SELV)
	Protection class UL	UL Class 2 Supply
	Degree of protection IEC/EN	IP54
	Degree of protection NEMA/UL	NEMA 2, UL Enclosure Type 2
	EMC	CE according to 2014/30/EU
	Certification IEC/EN	IEC/EN 60730-1 and IEC/EN 60730-2-14
	Certification UL	cULus according to UL 60730-1A, UL 60730-2-14 and CAN/CSA E60730-1:02
	Mode of operation	Type 1
	Rated impulse voltage supply / control	0.8 kV
	Control pollution degree	3
Ambient temperature	-30...50 °C	
Non-operating temperature	-40...80 °C	
Ambient humidity	95% r.h., non-condensing	
Maintenance	Maintenance-free	
<b>Weight</b>	Weight	0.26 kg

**Safety notes**

- The device must not be used outside the specified field of application, especially not in aircraft or in any other airborne means of transport.
- Outdoor application: only possible in case that no (sea)water, snow, ice, insolation or aggressive gases interfere directly with the actuator and that is ensured that the ambient conditions remain at any time within the thresholds according to the data sheet.

## Safety notes

- Only authorised specialists may carry out installation. All applicable legal or institutional installation regulations must be complied during installation.
- The mechanical end stops for limiting the angle of rotation may only be removed for adjustment. They must always be mounted during operation.
- The device may only be opened at the manufacturer's site. It does not contain any parts that can be replaced or repaired by the user.
- Cables must not be removed from the device.
- To calculate the torque required, the specifications supplied by the damper manufacturers concerning the cross-section, the design, the installation site and the ventilation conditions must be observed.
- The device contains electrical and electronic components and must not be disposed of as household refuse. All locally valid regulations and requirements must be observed.

## Product features

<b>Mode of operation</b>	The actuator is connected with a standard modulating signal of DC 0...10V and drives to the position defined by the positioning signal. Measuring voltage U serves for the electrical display of the damper position 0...100% and as slave control signal for other actuators.
<b>Simple direct mounting</b>	The actuator with its hollow spindle is mounted in a form-fit manner directly on the damper spindle and can be optionally secured with the Z-ARCM anti-rotation clip to prevent it from rotating.
<b>Manual override</b>	Manual override with magnet possible (the gear is disengaged as long as the magnet adheres to the magnet symbol). The magnet for gear disengagement is integrated in the position indication.
<b>Adjustable angle of rotation</b>	Adjustable angle of rotation with mechanical end stops.
<b>High functional reliability</b>	The actuator is overload protected, requires no limit switches and automatically stops when the end stop is reached.
<b>Hidden synchronisation</b>	If the actuator drives to the lower end stop during ongoing operation, then it performs a synchronisation of the positioning signal at DC 2 V. This ensures that the signal range also corresponds to the effective functional range in ongoing operation. The bottom end stop is actively approached as soon as the positioning signal is < DC 2.1 V. The actuator drives to the new specified position as soon as the positioning signal is once again > DC 2.3 V.

## Accessories

	Description	Type
<b>Mechanical accessories</b>	Anti-rotation clip for CM..	Z-ARCM
	Magnet disengagement	Z-MA
	Position indicator CM..	Z-PICM
	End stop clips CM.. / CQ..	Z-ESCM

## Electrical installation



- Notes**
- Connection via safety isolating transformer.
  - Parallel connection of other actuators possible. Observe the performance data.

Electrical installation

Wiring diagrams

AC/DC 24 V, modulating

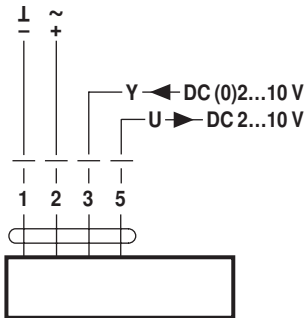

**Cable colours:**  
 1 = black  
 2 = red  
 3 = white  
 5 = orange

Dimensions [mm]

Spindle length

	Min. 25
	-

Dimensional drawings

